

X 7 6 S E R I E S

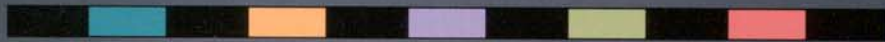

Environmental Monitors and Controls



ENVIRONMENTAL SENSORS AND PROBES

- JT-H2B** — Pipeline Leak Sensor for 2" pipelines
- JT-H3B** — Pipeline Leak Sensor for 3" pipelines
- LS-3** — Vertical Liquid Sensor for DW steel tanks, sumps, overflow protection
- LS-3s** — Vertical Liquid Sensor for DW steel tanks, sumps, overflow protection with test cable
- LS-3ss** — Vertical Liquid Sensor for chemicals, 316 stainless steel
- LS-6EXP** — Dispenser Pan/Sump Leak Sensor
- LS-7** — Horizontal Liquid Sensor for dry interstice DW fiberglass tanks
- LS-7s** — Horizontal Liquid Sensor for dry interstice DW fiberglass tanks with test cable
- LS-8** — Ground Water Sensor and Sump Sensor
- LS-30** — Dual Level Reservoir Sensor for wet interstice tanks
- JT-2P** — Tank Leak Sensor for pressurized DW tanks
- JT-2V** — Tank Leak Sensor for vacuum DW tanks
- HVA** — Mini Vertical Liquid Sensor for confined spaces
- 95C40(x)B** — In-Tank Gauge Probe for most liquids
- 95140(x)B** — In-Tank Gauge Probe for chemicals

COMMERCIAL & INDUSTRIAL LEVEL SENSORS

- LS39** — Brass or Stainless Steel Level Switch N.O. or N.C., with stainless steel float, 1/8" NPT
- LS40** — Multi-Level Level Switch, custom built
- LS41** — Brass or Stainless Steel Level Switch with stainless steel float, 1" NPT
- LS42** — Polysulfone, Polypropylene, Brass or Stainless Steel Level Switch with polysulfone, polypropylene, BUNA-N or stainless steel float, 1/8" NPT or 3/8" 16
- LS44** — Polysulfone or Polypropylene Level Switch with polysulfone or polypropylene float, 1/2" NPT, 1/2" 13 or 5/8" 11
- LS45** — Brass or Stainless Steel Level Switch, 20VA or 100VA. with BUNA N float, 1/4" NPT
- LS47** — Stainless Steel Level Switch and float, 20VA or 100VA, 1/4" NPT
- LS48** — PVC Level Switch and float, 1/4" NPT
- LS49** — Brass or Stainless Steel Level Switch with BUNA N of stainless steel float, 1/8" NPT or 3/8" 24 2A

COMMERCIAL & INDUSTRIAL FLOW SENSORS

- FS11** — Bronze or Stainless Steel Flow Switch, 3/4" to 3" pipe, 0.5 to 100 GPM
- FS12** — Adjustable Bronze Flow Switch, 1" pipe, 0.75 to 15.0 GPM
- FS13** — Bronze Flow Switch, 3/4" pipe, 0.75 to 10.0 GPM
- FS14** — Adjustable Bronze Flow Switch, 3/4" pipe, 0.75 to 14.0 GPM
- FS15** — Adjustable Bronze or Stainless Steel Flow Switch, 1/2" pipe, liquid or gas, 0.5 to 20.0 GPM or 3 to 475 SCFM
- FS16** — Brass or Stainless Steel Flow Switch, 1/4" pipe, 0.1 to 1.5 GPM
- FS17** — Brass or Stainless Steel Flow Switch 1/4" pipe, 50 to 300 ccm
- FS18** — PVC Flow Switch, 1" slip fit, 0.5 to 1.0 GPM
- FS19** — Brass or Stainless Steel Flow Switch, 1/4" pipe, 0.1 to 1.5 GPM
- FS20** — Brass or Stainless Steel Flow Switch, 1/2" pipe, 0.5 to 3.0 GPM
- FS21** — Polysulfone Flow Switch, 9/16", 18 UNF-2B port, 0.1 to 1.5 GPM
- FS22** — Polysulfone Flow Switch, 9/16", 18 UNF-2B port, 0.1 to 0.75 GPM
- FS24** — Adjustable Brass or Stainless Steel Flow Switch, 1" to 3" pipe, 6.0 to 26.0 GPM
- FS25** — Adjustable Polysulfone Flow Switch, 1" to 3" pipe, 6.0 to 26.0 GPM
- FS26** — PVC Flow Switch, 2.0" slip fit, 0.5 to 2.0 GPM



WARRANTY

Ronan warrants equipment of its own manufacture to be free from defects in material and workmanship, under normal conditions of use and service, and will replace any component found to be defective, on its return, transportation charges prepaid, within one year of its original purchase. This warranty carries no liability, either expressed or implied, beyond our obligations to replace the unit which carries the warranty.



Corporate Headquarters RONAN ENGINEERING COMPANY

P.O. Box 1275
21200 Oxnard Street
Woodland Hills,
California 91367 U.S.A.
(818) 883-5211 • (800) 327-6626
FAX (818) 992-6435

RONAN ENGINEERING LEAK DETECTION DIVISION

P.O. Box 1275
21200 Oxnard Street
Woodland Hills,
California 91367 U.S.A.
(818) 883-5211 • (800) 327-6626
FAX (818) 992-6435

RONAN ENGINEERING LTD. U.K.

1 Tilley Road
Crowther Industrial Estate
Washington, Tyne and Wear
United Kingdom, NE38-OEA
(191) 416-1689
FAX (191) 416-5856

RONAN ENGINEERING LIMITED

32 Bermondsey Road
Toronto, Ontario
Canada M4B1Z5
(416) 752-0310
FAX (416) 752-8072

RONAN ENGINEERING (AUST.) PTY. LTD.

Unit 10, 8 Leighton Place
Hornsby, N.S.W. 2077
Australia
(02) 477-7344
FAX (02) 477-6151

Series X76S Leak Detector System



Features

- Up to 4 Input Modules with LED Indicators
- Audible and Visual Alarms
- Intrinsically Safe Interface to Sensor
- Field-Proven Circuit Design
- NEMA Type 1 Enclosure
- Rugged Mechanical Design
- Liquid Level Sensors
 - High Reliability
 - UL Listed
 - Compatible with Hydrocarbons
 - Maintenance Free
- Alarm Contact Output per Sensor for Remote Indication or Telemetry
- Hydrostatic Leak Detector for Double-wall Tanks
- Positive Pressure Sensor for Pressurized Double-wall Tanks



Approved



Listed 48RO

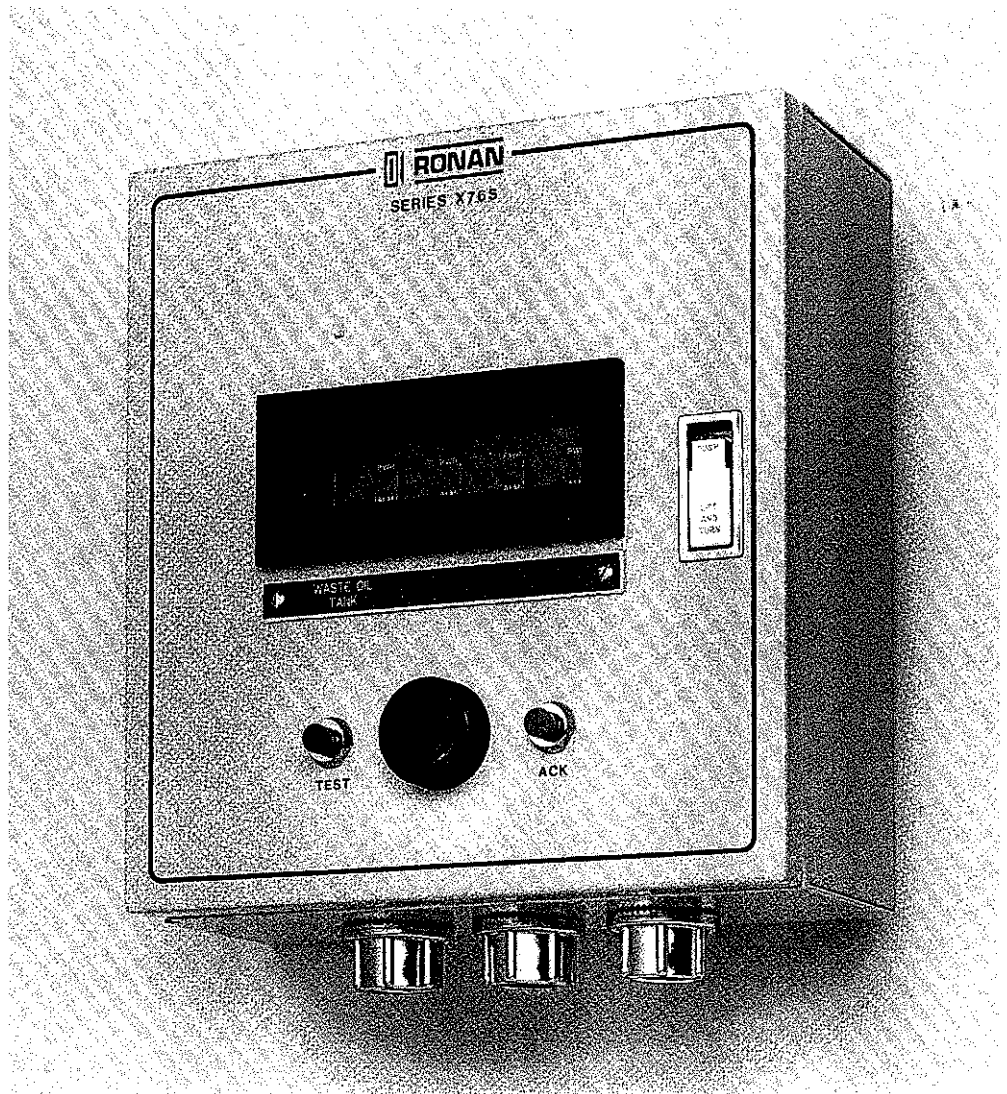

The Model X76S Leak Detector System continuously monitors underground storage tank installations for leakage of gasoline, diesel oil, waste oil and other hydrocarbons.

Two types of Liquid Level Sensors are horizontally or vertically positioned in the normally dry annular space of double-walled tanks. Upon accumulation of product due to a leak, the sensor will provide an audible and visual alarm.

Hydrostatic and air pressure sensors can provide

monitoring of both the outer or inner shell of a double-wall tank.

The sensor's outputs are continuously supervised by individual alarm modules via FM approved intrinsically safe barriers. This allows installation of the sensors in Class I, Division 1, Groups C, or D areas as defined in the National Electrical Code, without using costly conduits, conduit seals and explosion proof junction boxes.

The X76S provides up to four sensor alarms.

Series X76S Leak Detector System

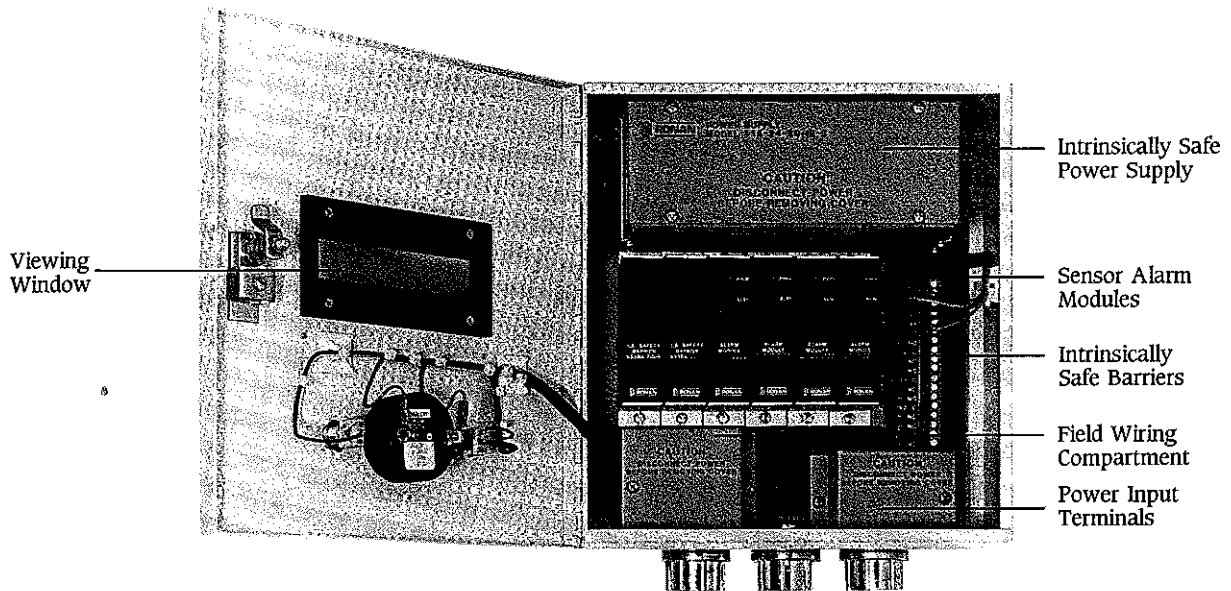

The Sensors

Model LS-3 N.C. & HVA Tank Level Sensors

The Model LS-3 N.C. is most suitable for steel, double-wall tanks. The unit is positioned vertically on the bottom of the tank annulus or at maximum fuel level of a tank to prevent overflow. The all-polysulfone level switch features a single-pole, single-throw contact, actuated by the float of the unit. The contact status is annunciated on the X76S monitor.

The HVA is a miniature liquid sensor for use in restricted vertical riser applications.

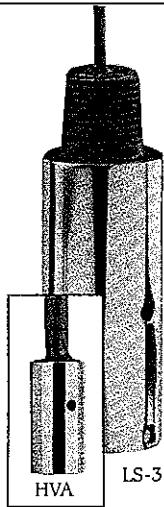

 Listed 48RO

Models LS-3 N.O. & LS-30 Hydrostatic Leak Detectors

The Models LS-3 N.O. and LS-30 Leak Detectors monitor any U.L. rated hydrostatic double-wall fiberglass tank reservoir.

Due to the possibility of groundwater seeping into a reservoir, the LS-30 is designed to detect liquid level gains as well as losses.

LS-10 and LS-20 Reservoir Assemblies are supplied when a permanent reservoir is not part of the tank package.

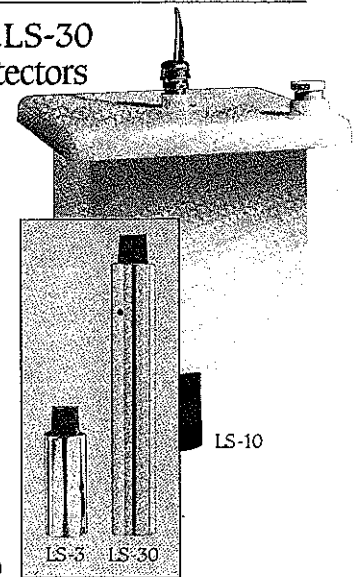

 Listed 48RO

Model LS-7 Tank Level Sensor

The Model LS-7 Level Switch is designed for horizontal applications where access is difficult, such as a dual-wall fiberglass tank's annulus. The unit is engineered to provide high-reliability point-level sensing. The plastic construction is compatible with all hydrocarbon liquids, providing long, trouble-free performance.

 Listed 48RO

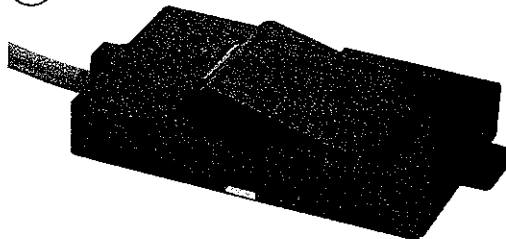

Model JT-2 Tank Leak Sensor

The Model JT-2 assembly consists of a pressure switch, fill valve and safety release valve. The Model JT-2P Positive Pressure Leak Sensor is designed to provide monitoring of the annular cavity of double-wall tanks via air pressure. Any breach of the containment will cause a pressure loss and will be sensed by the pressure switch transfiguring its contact should pressure fall below .5 PSIG.

The Model JT-2V Vacuum Leak Sensor monitors for loss of vacuum and will be sensed by the vacuum switch transfiguring its contact should vacuum fall to .5 inches of mercury.

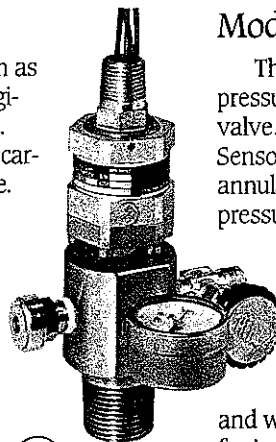

 Listed 48RO

Typical Installation

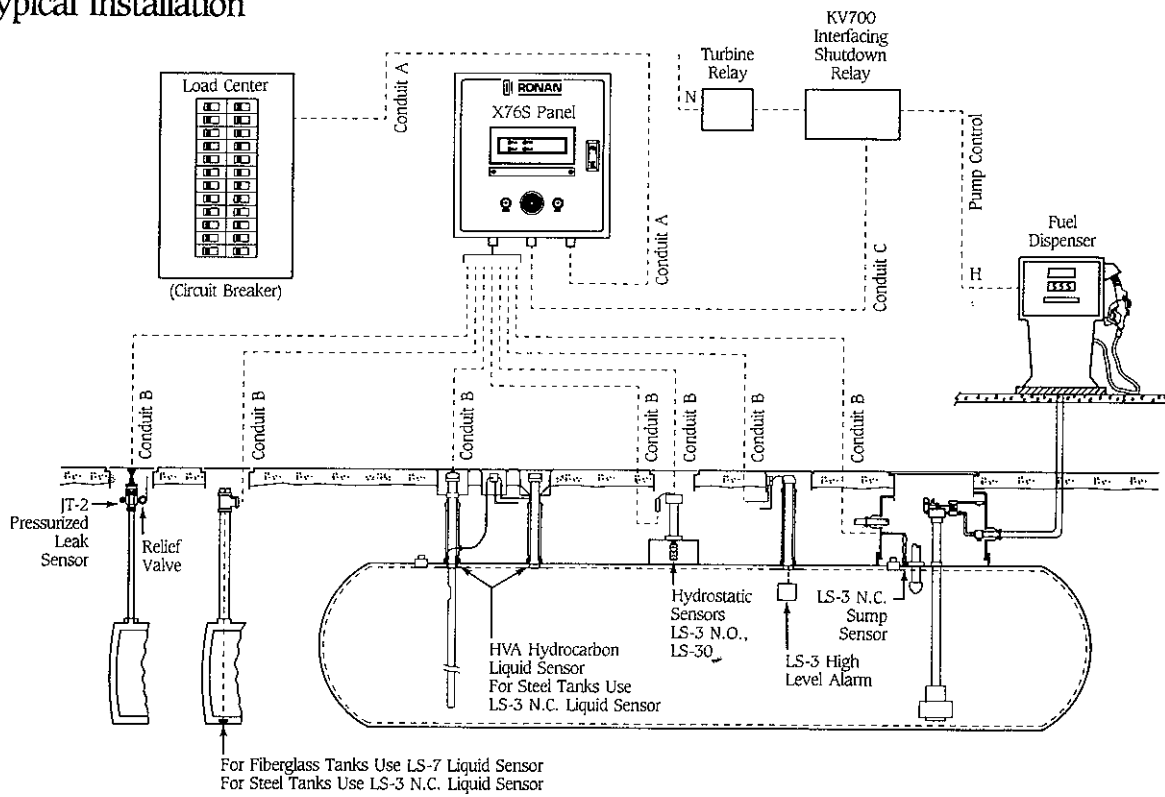

Wiring Information

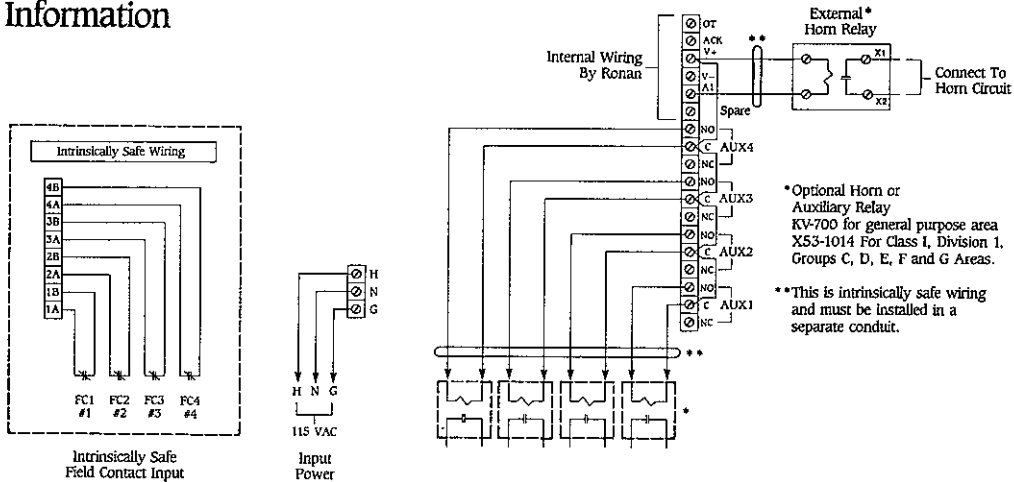

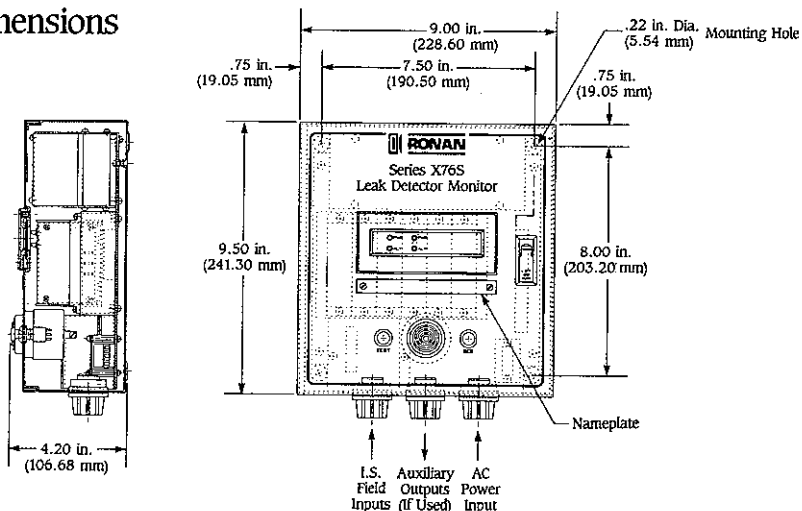

Mechanical Dimensions



Specifications



System, Model X76S

Power: 115 Vac, 60 Hz
 Power Consumption: 100 VA
 Operating Temperature: 32° to 165°F (0° to 75°C)
 Dimensions: 9×9.5×4.2 in. (22.86×24.13×10.67 cm)
 Mounting: General purpose area; wall mount

 Approved,  Listed 48RO



Alarm Module

Field Sensor: Dry contact
 Field Sensor Voltage: 115 Vac (supplied by X76S)
 Number of Inputs: One per module

 Approved,  Listed 48RO



Intrinsically Safe Barrier Module X53

Number of Inputs: Two per module
 Sensors Voltage: 24 Vdc, current limited
 Sensors: Dry contact
 Output Interface to Alarm Module: Relay contact; normally open/normally closed; selectable
 Power Consumption: 750 mW per input
 Supply Voltage: 24 Vdc from I.S. power supply

 Approved,  Listed 48RO

Power Supply I.S. (Intrinsically Safe)

Power Input: 115 Vac
 Output Voltage: 24 Vdc

 Approved,  Listed 48RO

Tank Leak Sensor, Model LS-3 N.C.

Housing: 304 stainless steel
 Switch:
 Type: SPST N.C.
 Rating: 10 VA
 Float material: Buna-N
 Pressure: 50 PSIG maximum
 Leads: 20 AWG

 Listed 48RO

Tank Leak Sensor, Model LS-7

For steel and fiberglass double-wall tanks.
 Housing Material: PVC (Geon 87241)
 Liquid SpG: .70 minimum
 Switch:
 Type: SPST N.C.
 Rating: 10 VA
 Leads: 20 AWG

 Listed 48RO

Hydrostatic Tank Leak Detectors, Models LS-10 or LS-20

Reservoir:
 Volume:
 LS-10, two gallons (7.47 liters)
 LS-20, four gallons (15.14 liters)
 Material: Polyethylene plastic
 Switches: Model LS-3 N.O. and LS-30
 Type: LS-3 N.O., SPST; LS-30, DPDT
 Rating: 10 VA
 Float material: Buna-N

Pressure: 50 PSIG maximum

Leads: 20 AWG

 Listed 48RO

HVA Mini Liquid Vertical Riser Sensor

Housing: Stainless steel
 Contacts: Gold plated
 Float: Gold plated aluminum
 Type: Single pole, normally open
 Leads: 20 AWG

 Listed 48RO

Tank Leak Sensor, Model JT-2

Housing: Stainless steel, explosion proof, hermetically sealed, NEMA Types 7 and 9
 Classification:
 Class 1: Groups A, B, C and D
 Class 2: Groups E, F and G
 Switch:
 Type: SPDT N.O. (shelf condition)
 Rating: 10 VA
 Electrical Connection: ½ in.—14 NPT with PVC-insulated 18 AWG leads
 Pressure:
 Setpoint: JT-2 Positive Pressure Leak Sensor, .5 PSIG, JT-2V Vacuum Leak Sensor, .5 inches of mercury
 Connection: ¼ in.—18 NPT
 Adjustment: ⅛ in. Allen wrench through port
 Temperature Range: -40° to 180°F (-40° to 82°C)

 Listed 48RO; CSA Approved 34146

Ordering Information

The Ronan Model X76S Leak Detector Monitor System can be configured to meet the different local and state codes for underground storage by proper selection of sensors and monitor modules. For example, a particular local code and/or type of facility may require leak detection of a tank annulus. The monitor system would consist of the following items:

Model X76S-()-()-()

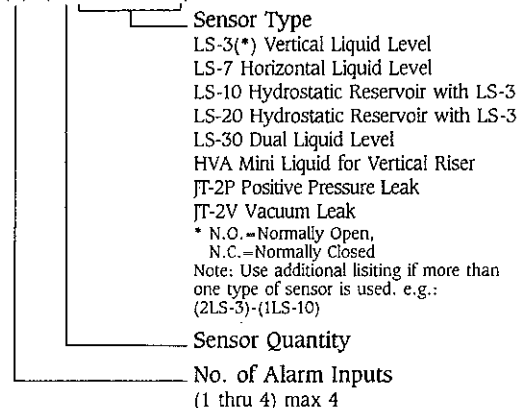

Warranty: Ronan warrants equipment of its own manufacture to be free from defects in material and workmanship under normal conditions of use and service, and will repair or replace any component found to be defective, on its return, transportation charges prepaid, within one year of its original purchase. This warranty carries no liability, either expressed or implied, beyond our obligation to replace the unit which carries the warranty.



RONAN ENGINEERING COMPANY
 21200 Oxnard Street
 Woodland Hills
 California 91367 U.S.A.
 (818) 883-5211
 (800) 327-6626
 FAX (818) 992-6435

RONAN ENGINEERING LIMITED U.K.
 1 Tilley Road
 Crowther Industrial Estate
 Washington, Tyne and Wear
 United Kingdom, NE38-OEA
 (191) 416-1689
 FAX (191) 416-5856

RONAN ENGINEERING LIMITED
 32 Bermondsey Road
 Toronto, Ontario
 Canada M4B1Z5
 (416) 752-0310
 FAX (416) 752-8072

RONAN ENGINEERING PTY. LTD.
 Unit 10, 8 Leighton Place
 Hornsby, N.S.W. 2077
 Australia
 (02) 477-7344
 FAX (02) 477-6151

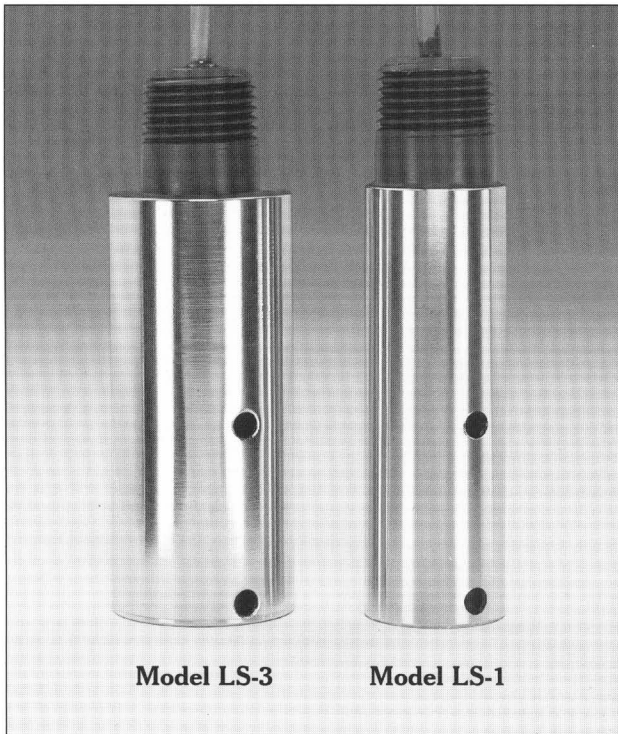

S E R I E S X 7 6

Vertical Liquid Sensors Models LS-3/-3s/-3ss

Ronan's Model LS-3 Vertical Liquid Sensor and the variations LS-3s and LS-3ss are designed to detect changes in liquid level within reservoirs or the intrusion of liquid in dry containment zones and caisson compartments where vertical positioning of the sensor is allowed. The LS-3 is constructed of 304 and 316 stainless steel, polysulfone, Buna-N and PVC. The LS-3s includes an integral Pull-to-Test cable, required in some jurisdictions. The LS-3ss Sensor is constructed of 304 and 316 stainless steel and Teflon, and is designed for use in chemical applications where corrosion is a concern. All LS-3 sensors are designed to provide years of trouble-free service.

All LS-3 sensors have user selectable logic and may be installed in wet or dry conditions. Liquid collection or loss, sufficient to move the float will transmit a signal to the control panel to initiate control functions or annunciate alarms. The LS-3's design allows rigid or flexible mounting to allow easy periodic testing as required by many regulatory agencies. The sensor may be mounted loosely suspended by its cable or rigid with the 1/2 inch NPT nipple.

Typical Applications

- DW Steel Tank Interstice Monitoring
- Piping Containment Sumps
- Sub-pump Containment Sumps
- Fill Riser Containment Sump
- High Level/Overfill Monitoring
- Vertical Application Point Level Sensing
- Where Ground Level Testing is Required
- Corrosive Chemical Monitoring

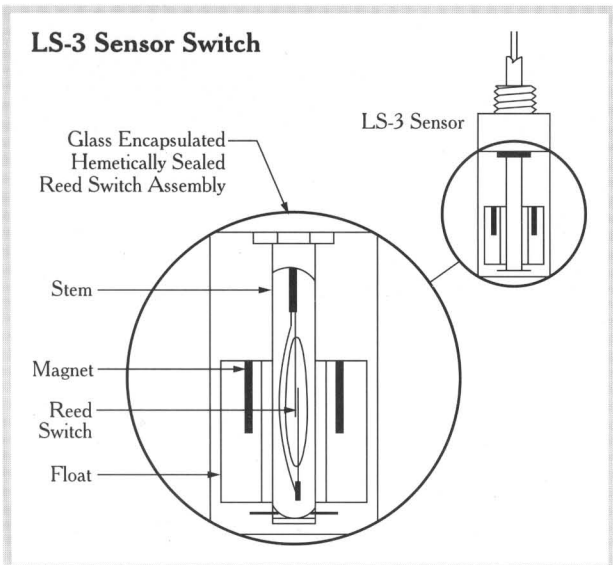

Dependable, Simple Operation

Ronan's LS-3 Sensors operate on a direct principle. A glass encapsulated hermetically sealed reed switch is embedded within the sensor stem. Permanent magnets within the sensors float create a magnetic field which surrounds the reed switch holding the switch closed. When the magnetic field is removed by movement of the float, the reed switch is actuated, thereby changing the state. This condition either opens a closed switch or closes an open switch. This change in state is then signaled to the control panel.

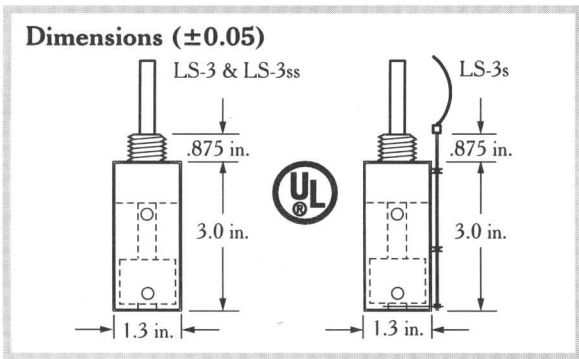

Specifications

Specifications are subject to change without notice. Contact Ronan Engineering to verify critical specifications.

Wetted Parts: 304 and 316 Stainless Steel, Buna-N, Polysulfone, PVC, Teflon

Mounting: 1/2 inch NPT, male

Switch Rating: SPST, 20VA, 120-240 Vac pilot duty

Operating Temperature: -40°F to +180°F (LS-3 & LS-3s)
-40°F to +300°F (LS-3ss)

Float S.G.: 0.55 (LS-3 & -3S), 0.77 (LS-3ss)

Pressure: 150 psi maximum (LS-3 & LS-3s)
400 psi maximum (LS-3ss)

Cable: PVC or Teflon jacket, twisted pair, 20AWG, 22 ft

Options

LS-3s: Includes integral Pull-to-Test cable, required in some jurisdictions

LS-3ss: Stainless steel version for chemical applications. Supplied with 316 SS float and stem

LS-1: Typical LS-3 with 1 inch O.D. for restricted clearances

Ordering Information

Part No.	Description
LS-3	Standard Vertical Liquid Sensor with normally open contacts
LS-3NO*	Standard Vertical Liquid Sensor, with normally closed contacts
LS-3s	Vertical Liquid Sensor, with Pull-to-Test cable
LS-3sNO*	Vertical Liquid Sensor, with Pull-to-Test cable and normally open contacts
LS-3ss**	Chemical compatible Vertical Liquid Sensor
LS-3ssNO*	Chemical compatible Vertical Liquid Sensor with normally open contacts
LS-1	1.0 inch O.D. Vertical Liquid Sensor
LS-1NO*	1.0 inch O.D. Vertical Liquid Sensor with normally open contacts

* Unless specified otherwise, LS-3 sensors ship with NC contacts.

** Consult factory for chemical compatibility and specific gravity requirements.

Typical Wiring Diagrams

X76LVC, X76LVCS, X76-4X & X76AST-4X Systems

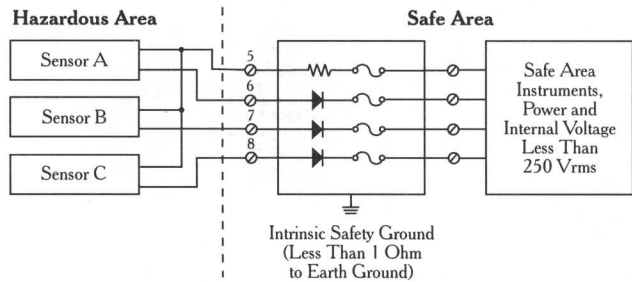

X76S System

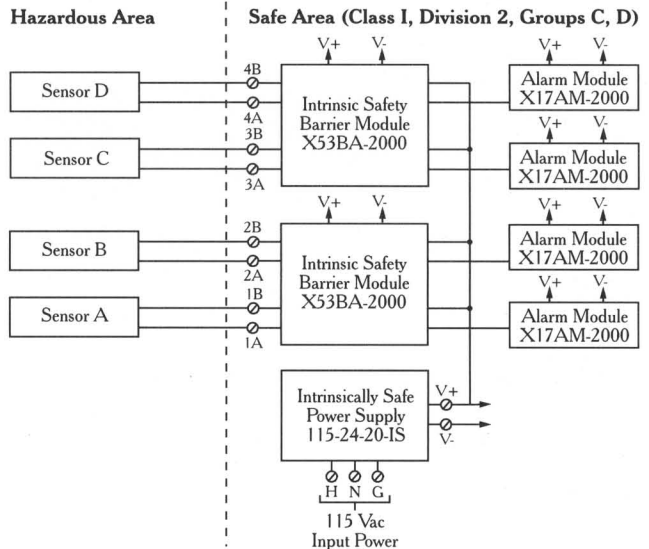

X76ETM-4X & X76ETM Systems

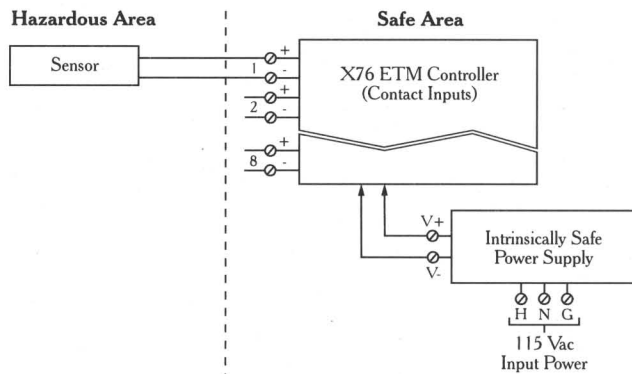

MEMBER
PEI
PETROLEUM EQUIPMENT INSTITUTE

For additional information, catalogs and pricing, contact your local Ronan distributor or call 800-32-ROANAN.

RONAN

**Ronan Engineering Company
Leak Detection Measurements Division**

21200 Oxnard Street, Woodland Hills, California 91367

818.883-5211 FAX: 818.992.6435

http://www.ronan.com E-mail: info@ronan.com

LS-3/-3s/-3ss/Rev. 1

Printed in U.S.A.

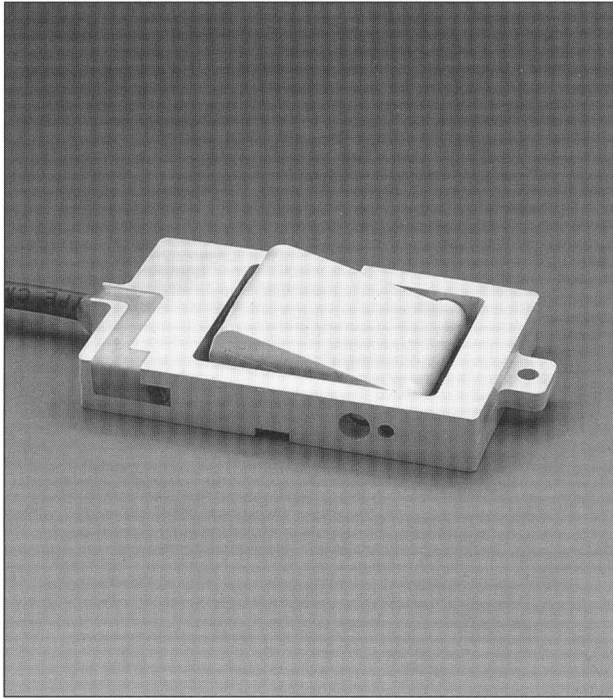

Typical Applications

- DW Fiberglass Tank Dry Interstice Monitoring
- DW Piping Containment Sumps
- Horizontal Application Point Level Sensing
- Restricted Vertical Clearance
- Where Ground Level Testing is Required

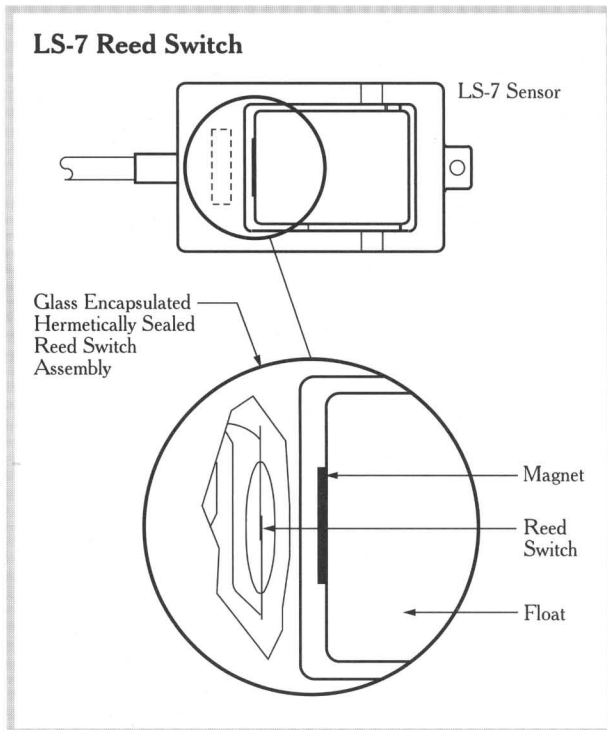

S E R I E S X 7 6

Horizontal Liquid Sensor Model LS-7/-7s

Ronan Engineering's Models LS-7s and LS-7s Horizontal Liquid Sensors are designed to detect the intrusion of liquid in dry interstice DW fiberglass tanks, containment zones and caisson compartments where horizontal positioning of the sensor is preferred. The integral Pull-to-Test cable on the LS-7s, required in some jurisdictions, allows sensor testing from ground level. Constructed of PVC the LS-7 and LS-7s will provide years of trouble-free service.

The LS-7's unique design cannot be installed upside down as is the case with sensors from other manufacturers. Liquid collection sufficient to raise the sensor float will transmit a signal to the control panel to initiate control functions or annunciate alarms.

The LS-7's thin cross section makes it ideal for applications where limited vertical clearance is available. The sensor may be installed in any horizontal application where there is 0.625 inches of vertical clearance.

Dependable Simple Operation

Ronan's LS-7 Sensor operates on a direct principle. A glass encapsulated, hermetically sealed, reed switch is embedded within the sensor body. A permanent magnet in the sensors float creates a magnetic field which surrounds the reed switch holding the switch closed. When the magnetic field is removed by moving the float, the reed switch is actuated, thereby changing state. This condition opens a closed switch. This change in state is then signaled to the control panel.

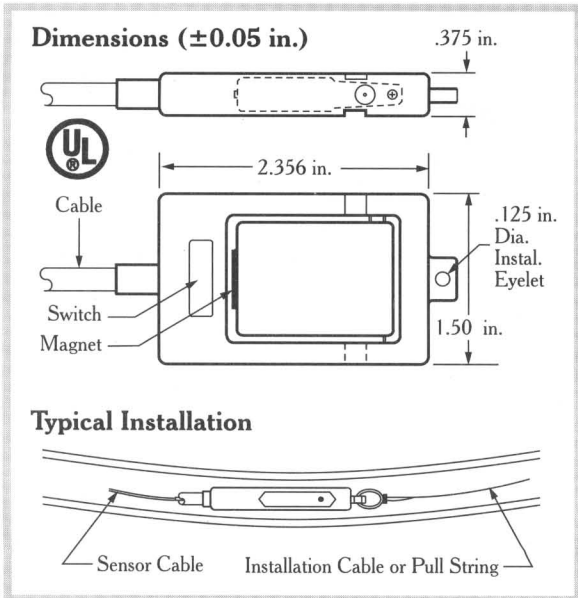

Specifications

Specifications are subject to change without notice. Contact Ronan Engineering to verify critical specifications.

Wetted Parts: PVC (Geon 87241)

Installation: Horizontal, 0.635 inch minimum vertical clearance

Switch Rating: SPST 10VA, 120-240Vac pilot duty

Operating Temperature: -40°F to $+140^{\circ}\text{F}$

Liquid S.G.: 0.70 minimum

Pressure: 50 psi maximum

Cable: PVC jacket, twisted pair, 20AWG, 25 ft

Options

LS-7: Standard Horizontal Liquid Sensor

LS-7s: Horizontal Liquid Sensor, with integral Pull-to-Test cable

Ordering Information

Part No. Description

LS-7 Standard Horizontal Liquid Sensor with normally closed contacts

LS-7s Standard Horizontal Liquid Sensor with integral Pull-to-Test cable



Ronan Engineering Company
Leak Detection Measurements Division

21200 Oxnard Street, Woodland Hills, California 91367
818.883-5211 FAX: 818.992.6435

<http://www.ronan.com> E-mail: info@ronan.com

LS-7-7s/Rev. 1

Typical Wiring Diagrams

X76LVC, X76LVCS, X76-4X & X76AST-4X Systems

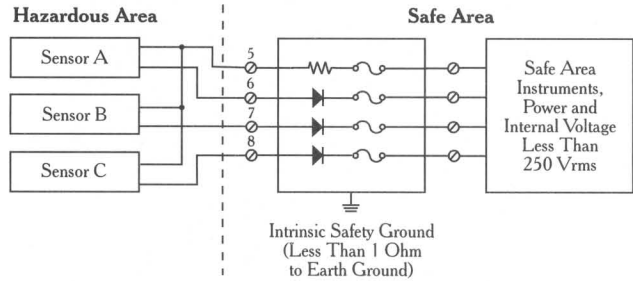

X76S System

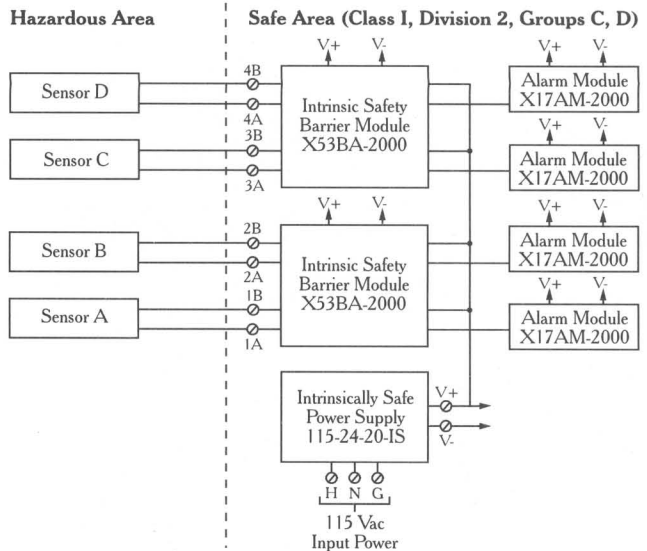

X76ETM-4X & X76ETM Systems

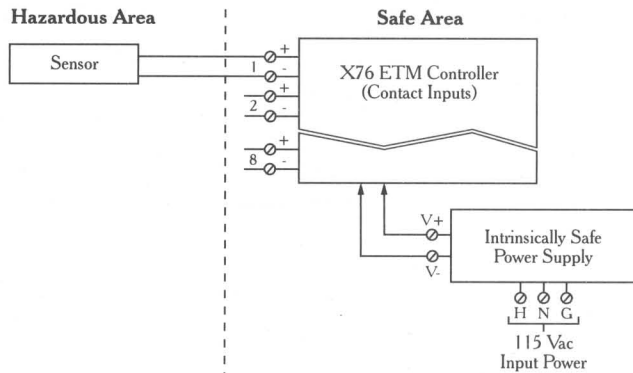

For additional information, catalogs and pricing, contact your local Ronan distributor or call 800-32-ROAN.

S E R I E S X 7 6

Hydrostatic Reservoir Sensor Model LS-30

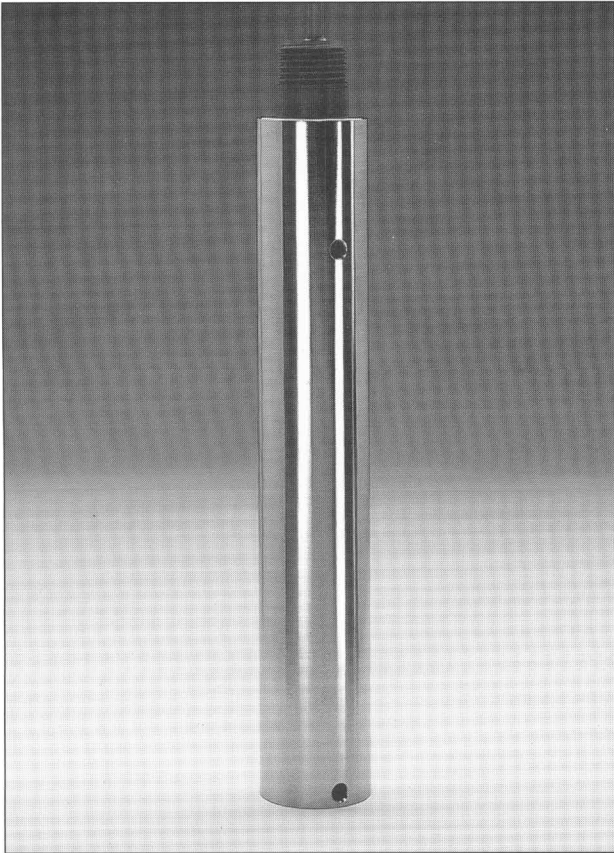

Ronan's Model LS-30 Hydrostatic Reservoir Leak Sensor is designed to detect changes in liquid level within reservoirs of hydrostatic monitored double-wall tanks. Constructed of 304 stainless steel, polysulfone, Beryllium Copper and PVC, the LS-30 will provide years of trouble-free service.

The LS-30 can be installed to provide discrete indications of liquid increase or liquid loss, or provide high either/ or low liquid indications. A breach of the tanks inner wall will allow reservoir liquid to escape the interstice into the primary tank, and a reservoir level drop will occur. A breach of the outer tank wall will allow reservoir liquid to escape the interstice into the environment, or ground water to enter the interstice, and a reservoir level change will occur. Liquid increase or loss, sufficient to move the sensor's float will transmit a signal to the control panel to initiate control functions or annunciate alarms.

Typical Applications

- DW Fiberglass Tank Reservoir Monitoring
- Low and Low Low Level Monitoring
- High Level/Overfill Monitoring
- Vertical Application Dual Point Level Sensing

Dependable, Simple Operation

Ronan's LS-30 Sensor operates on a direct principle. Glass encapsulated, hermetically sealed, reed switches are embedded within the sensor stem. Permanent magnets within the sensor floats create a magnetic field which surrounds the reed switches. When a magnetic field is removed by movement of one or both floats, the reed switch is actuated, thereby changing state. This condition either opens a closed switch or closes an open switch. This change in state is then signaled to the control panel.

Application

The LS-30's design allows rigid or flexible mounting for easy periodic testing as required by many regulatory agencies. The sensor may be mounted loosely suspended by its cable, or rigid with the 1/2 inch NPT nipple. The LS-30 may also be supplied with the optional RC-4 four inch riser cap assembly. The LS-30 is supplied with the low circuit N.O. and the high circuit N.C. Other logic configurations are available by specifying at time of order.

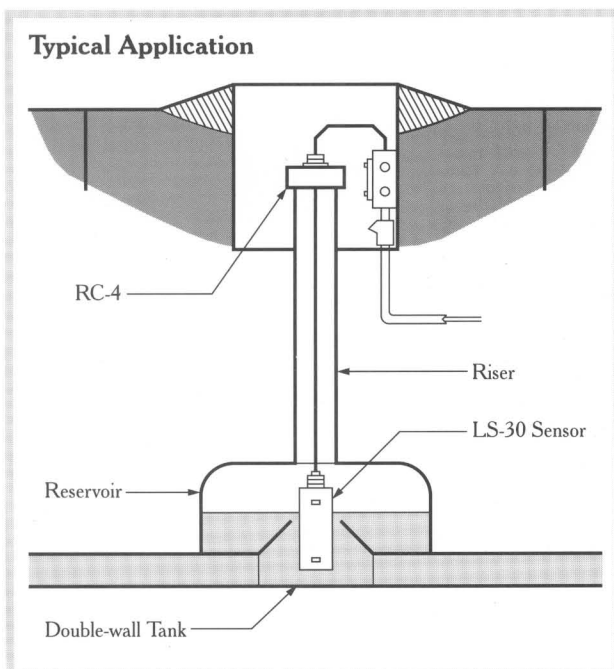

**Dimensions
(±0.05 in.)**

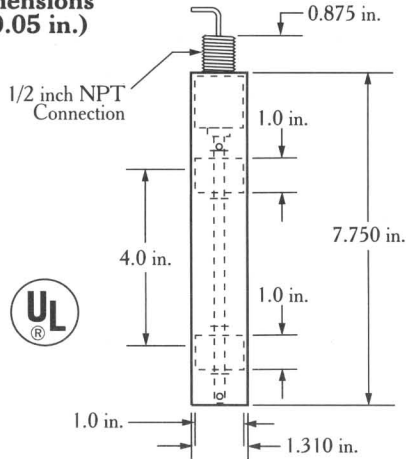

Specifications

Specifications are subject to change without notice. Contact Ronan Engineering to verify critical specifications.

Wetted Parts: 304 and 316 Stainless Steel, Beryllium Copper, Polysulfone, PVC

Mounting: 1/2" NPT, male

Switch Rating: SPST, 20VA, 120-240 Vac pilot duty

Operating Temperature: -40°F to +225°F

Float S.G.: 0.65

Pressure: 75 psi maximum

Cable: PVC jacket, 2 twisted pair, 20AWG, 15 ft

Options

RC4: 4" PVC riser cap with cable grip and vent port

Ordering Information

Part No.	Description
LS-30	Standard Hydrostatic Reservoir Sensor
LS-30LL	Dual Point Low/Low Low Level Sensor
LS-30HH	Dual Point High/High Level Sensor



Ronan Engineering Company
Leak Detection Measurements Division
 21200 Oxnard Street, Woodland Hills, California 91367
 818.883-5211 FAX: 818.992.6435
<http://www.ronan.com> E-mail: info@ronan.com

LS-30/Rev. 1

Typical Wiring Diagrams

X76LVC, X76LVCS, X76-4X & X76AST-4X Systems

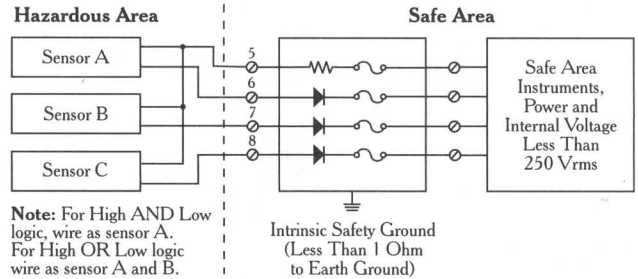

X76S System

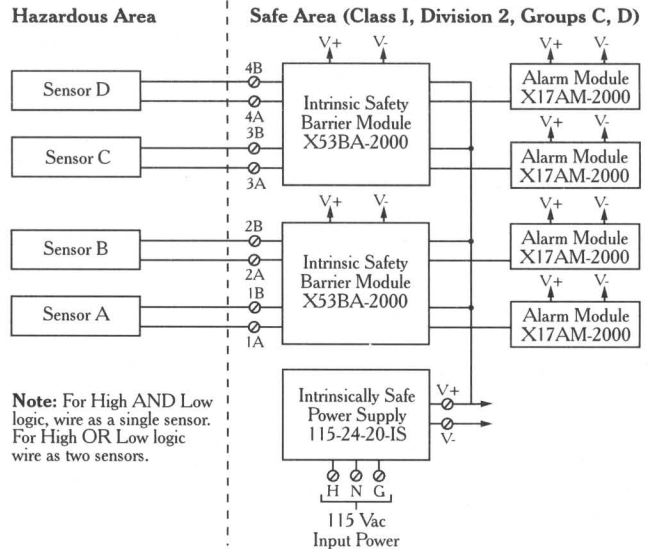

X76ETM-4X & X76ETM Systems

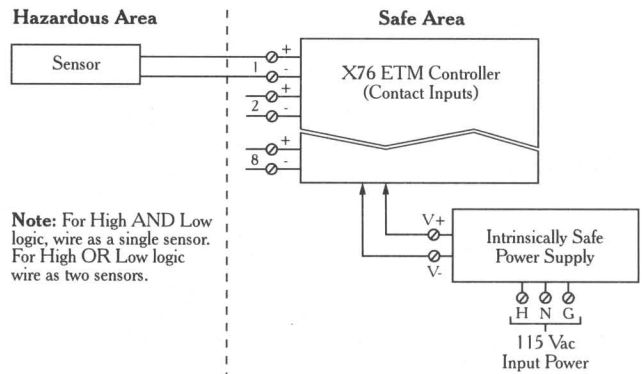

For additional information, catalogs and pricing, contact your local Ronan distributor or call 800-32-RONAN.